

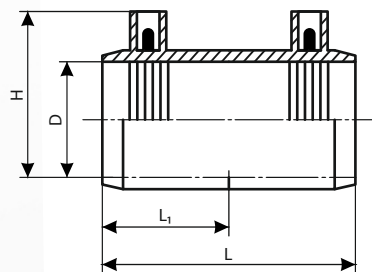

Муфта электросварная ALLURE



№ п/п	Диаметр	D	L	L ₁	H	Вес изделия, 1 шт. в гр.
1	25	25	74	37	53	43
2	32	32	91	45	60	70
3	50	50	84	40	83	140
4	63	63	101	50	96	230
5	90	90	140	70	130	560
6	110	110	155	77	150	800
7	160	160	179	89	227	1600
8	200	200	215	107	260	3450
9	225	225	225	112	285	4200
10	250	250	240	120	320	5460
11	315	315	270	134	397	10160

Переход электросварной ALLURE

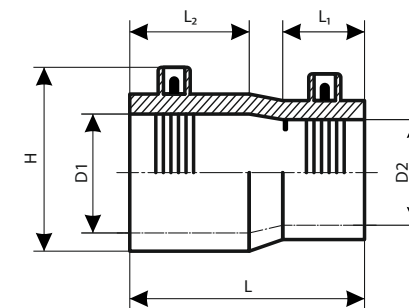

№ п/п	Диаметр	D1	D2	L	L ₁	L ₂	H	Вес изделия, 1 шт. в гр.
1	63x32	63	32	153	48	67	96	240
2	63x40	63	40	146	50	67	96	250
3	63x50	63	50	143	50	67	96	260
4	110x63	110	63	187	63	77	153	755
5	110x90	110	90	182	68	79	155	860